

**BOCCELLO A GETTO PIENO/NEBULIZZATO ACQUA /  
SCHIUMA Mod. FI – BA**  
JET / FOG WATER / FOAM NOZZLE Mod. FI - BA



**CARATTERISTICHE:**

- Corpo: in acciaio inox
- Attacco: Flangiato. A richiesta filettato gas M / F

**CHARACTERISTICS:**

- Body: stainless steel
- Connection: Flanged. On Req. threaded M / F

# BOCHELLO A GETTO PIENO/NEBULIZZATO ACQUA / SCHIUMA Mod. FI – BA 3-15

## JET / FOG WATER / FOAM NOZZLE Mod. FI - BA 3-15

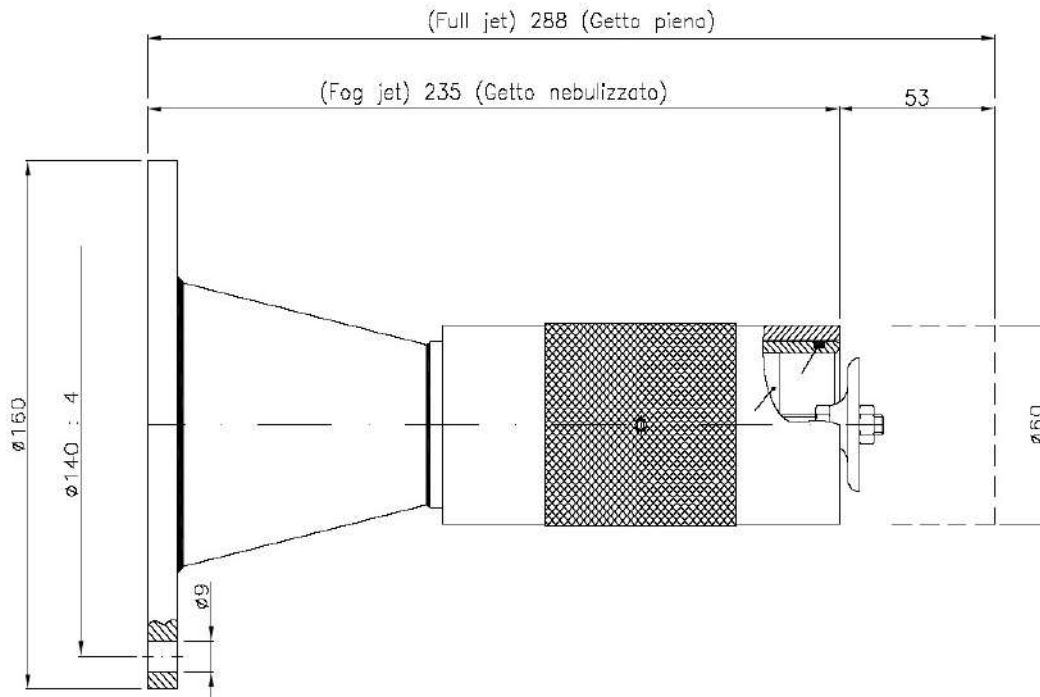

Model	PRESSURE IN BAR									
	5	6	7	8	9	10	11	12	13	14
	FLOW ( Lts./1' )									
<b>FI-BA 3</b>	292	320	346	369	392	413	433	453	471	489
<b>FI-BA 5</b>	455	499	539	576	611	644	675	705	734	762
<b>FI-BA 7</b>	659	722	780	833	884	932	977	1021	1062	1103
<b>FI-BA 9</b>	809	886	958	1024	1086	1145	1200	1254	1305	1354
<b>FI-BA 11</b>	994	1089	1177	1258	1334	1406	1475	1541	1604	1665
<b>FI-BA 13</b>	1173	1285	1389	1484	1574	1660	1741	1819	1893	1955
<b>FI-BA 15</b>	1341	1469	1587	1696	1800	1897	1989	2078	2163	2245

### Throw Curves Jet Mode

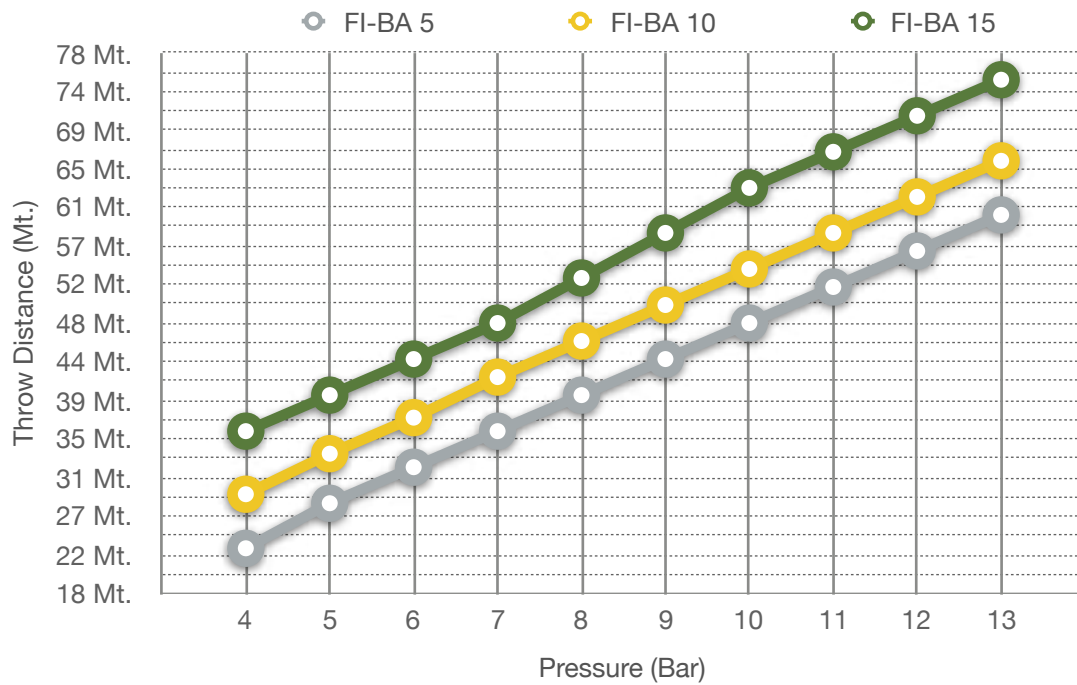

**BOCCELLO A GETTO PIENO/NEBULIZZATO ACQUA /  
SCHIUMA Mod. FI – BA 15-25 25-85**  
JET / FOG WATER / FOAM NOZZLE Mod. FI - BA 15-25 25-85

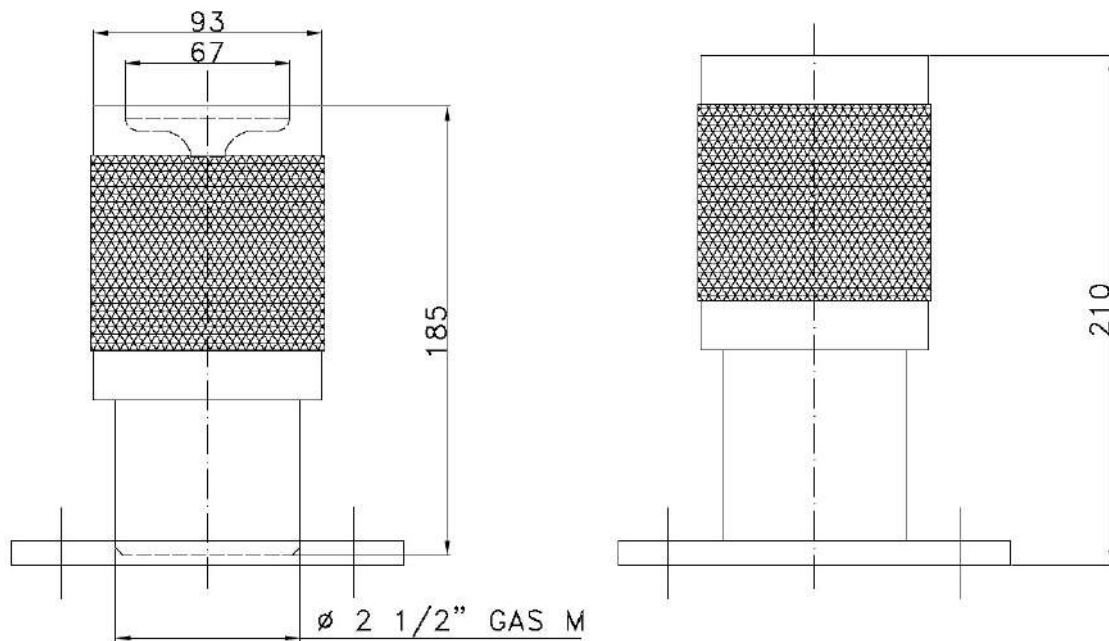

**CARATTERISTICHE:**

- Corpo: in acciaio inox
- Attacco: Flangiato. A richiesta filettato gas M / F

**CHARACTERISTICS:**

- Body: stainless steel
- Connection: Flanged. On Req. threaded M / F

MODELLO MODEL	PESO/ WEIGHT ( Kg. )	PORTATA FLOW RATE	MATERIALE MATERIAL
FI-BA 15-25	5	1500 – 2500	S.STEEL
FI-BA 25-85	8	2500 - 8500	S.STEEL

Model	PRESSURE IN BAR									
	5	6	7	8	9	10	11	12	13	14
	FLOW ( Lts./1' )									
<b>FI-BA 15</b>	1270	1390	1500	1605	1700	1795	1880	1965	2045	2120
<b>FI-BA 20</b>	1690	1850	2000	2140	2270	2390	2510	2620	2725	2830
<b>FI-BA 25</b>	2115	2315	2500	2675	2835	2990	3135	3275	3410	3535
<b>FI-BA 30</b>	2535	2780	3000	3210	3400	3585	3760	3930	4090	4245
<b>FI-BA 35</b>	2960	3240	3500	3740	3970	4180	4390	4580	4770	4950
<b>FI-BA 40</b>	3380	3700	4000	4275	4535	4780	5015	5235	5450	5655
<b>FI-BA 45</b>	3800	4165	4500	4810	5100	5380	5640	5890	6130	6360
<b>FI-BA 50</b>	4225	4630	5000	5345	5670	5975	6265	6545	6815	7070
<b>FI-BA 55</b>	4649	5092	5500	5908	6237	6574	6895	7202	7496	7779
<b>FI-BA 60</b>	5071	5555	6000	6415	6804	7172	7522	7857	8177	8486
<b>FI-BA 65</b>	5494	6018	6500	6949	7371	7770	8149	8511	8859	9193
<b>FI-BA 70</b>	5939	6481	7000	7484	7938	8367	8776	9166	9540	9900
<b>FI-BA 75</b>	6339	6944	7500	8019	8505	8965	9403	9821	10222	10608
<b>FI-BA 80</b>	6762	7407	8000	8553	9072	9563	10029	10475	10903	11315
<b>FI-BA 85</b>	7184	7870	8500	9088	9639	10160	10656	11130	11585	12022

### Throw Curves Jet Mode

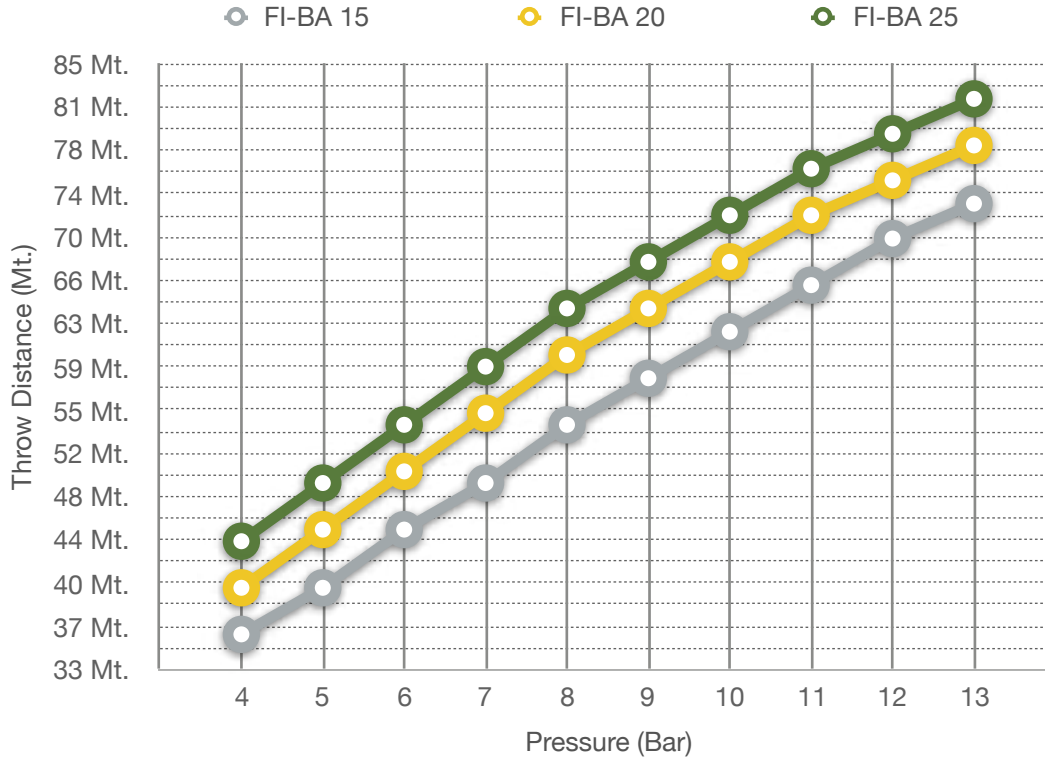

### Throw Curves Jet Mode

